

**CONFIDENTIAL**



**UTHM**  
Universiti Tun Hussein Onn Malaysia

**UNIVERSITI TUN HUSSEIN ONN MALAYSIA**

**FINAL EXAMINATION  
(ONLINE)  
SEMESTER I  
SESSION 2020/2021**

COURSE NAME : CONTROL SYSTEM  
COURSE CODE : DAE 32103  
PROGRAMME CODE : DAE  
EXAMINATION DATE : JANUARY / FEBRUARY 2021  
DURATION : 4 HOURS  
INSTRUCTION : ANSWER **FOUR (4)** QUESTIONS ONLY  
(OPEN BOOK EXAMINATION)

THIS QUESTION PAPER CONSISTS OF TWELVE (12) PAGES

**TERBUKA**  
**CONFIDENTIAL**

- Q1 (a) An aircraft's attitude varies in roll, pitch, and yaw as defined in **Figure Q1(a)**. The system measures the actual roll angle with a gyro and compares it with the desired roll angle. The ailerons respond to the roll angle error by undergoing an angular deflection. The aircraft responds to this angular deflection, producing a roll angle rate.

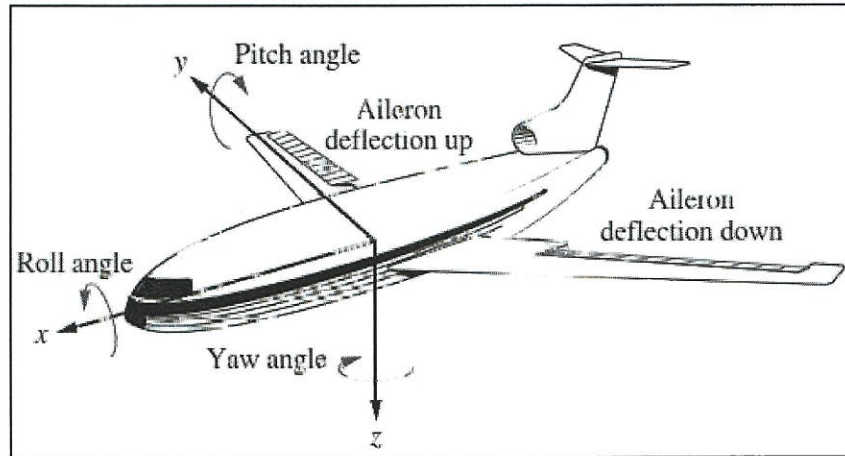

Figure Q1(a)

- (i) Draw a functional block diagram for a closed-loop system that stabilizes the roll. (5 marks)
- (ii) Identify input transducer, the controller, the plant and the output transducer. (4 marks)
- (b) An electrical tumble dryer shown in **Figure Q1(b)** is an open loop system because it doesn't consider the condition of clothes before it stops working. The user will decide the duration required for the drying time based on the amount of clothes to dry. For example, the timer is set at 20 minutes. As it is an automatic open loop system, the machine will stop working automatically after 20 minutes, irrespective of the nature of the clothes, whether the clothes are dry or damp.



Figure Q1(b)

**TERBUKA**

- (i) Draw the functional block diagram of the electrical tumble dryer. (4 marks)
  - (ii) Identify the input, the controller, the controller output, the process and the output of this system. (5 marks)
  - (iii) Suggest how to upgrade this system design into an intelligence system (monitors the state of clothes, whether they are dry or wet). (4 marks)
  - (iv) State the type of transducer used by the system in Q1(b)(ii) (1 mark)
- (c) List **two (2)** reasons why closed loop control system is better than open loop control system. (2 marks)

**Q2 (a) Figure Q2(a)** shows a schematic diagram of a closed loop drug delivery system for a diabetes patient. A sensor is utilized to measure the levels of the regulated drug or nutrient in blood. This measurement is converted to digital form and fed to the control computer which drives a pump that system injects the drug into the patient's blood.

Draw a digital closed loop drug delivery control system.

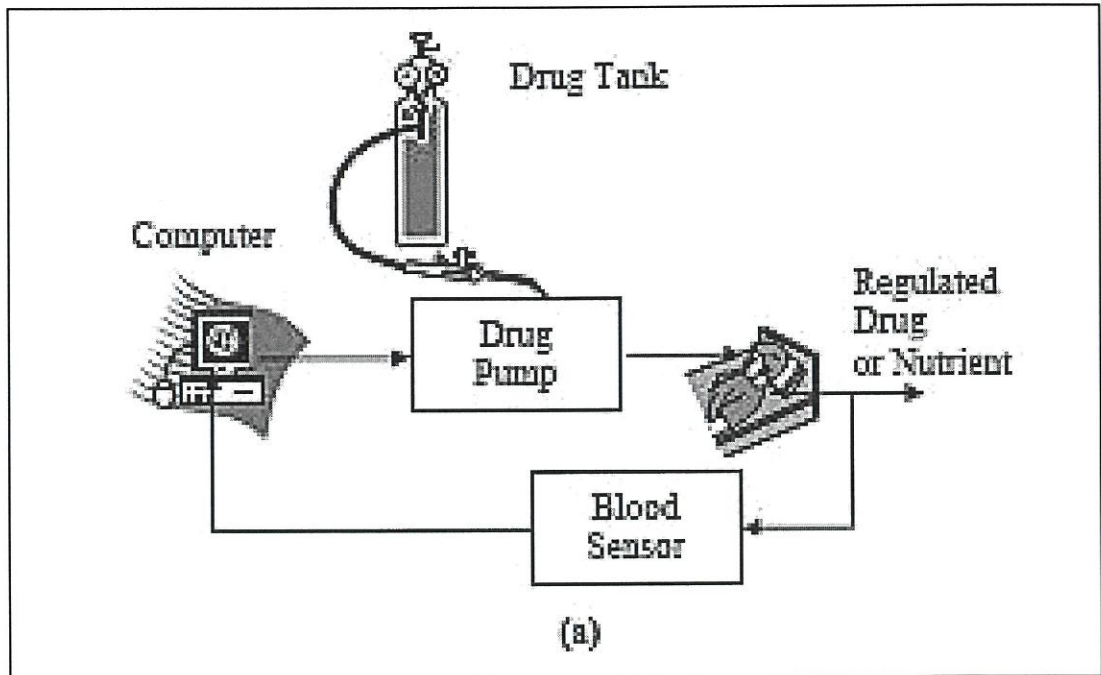

Figure Q2(a)

(4 marks)

**TERBUKA**



- (b) **Figure Q2(b)** shows a position control system using a microprocessor-based controller with parallel ports. This particular system has one output port and three input ports. Explain the function of each port.

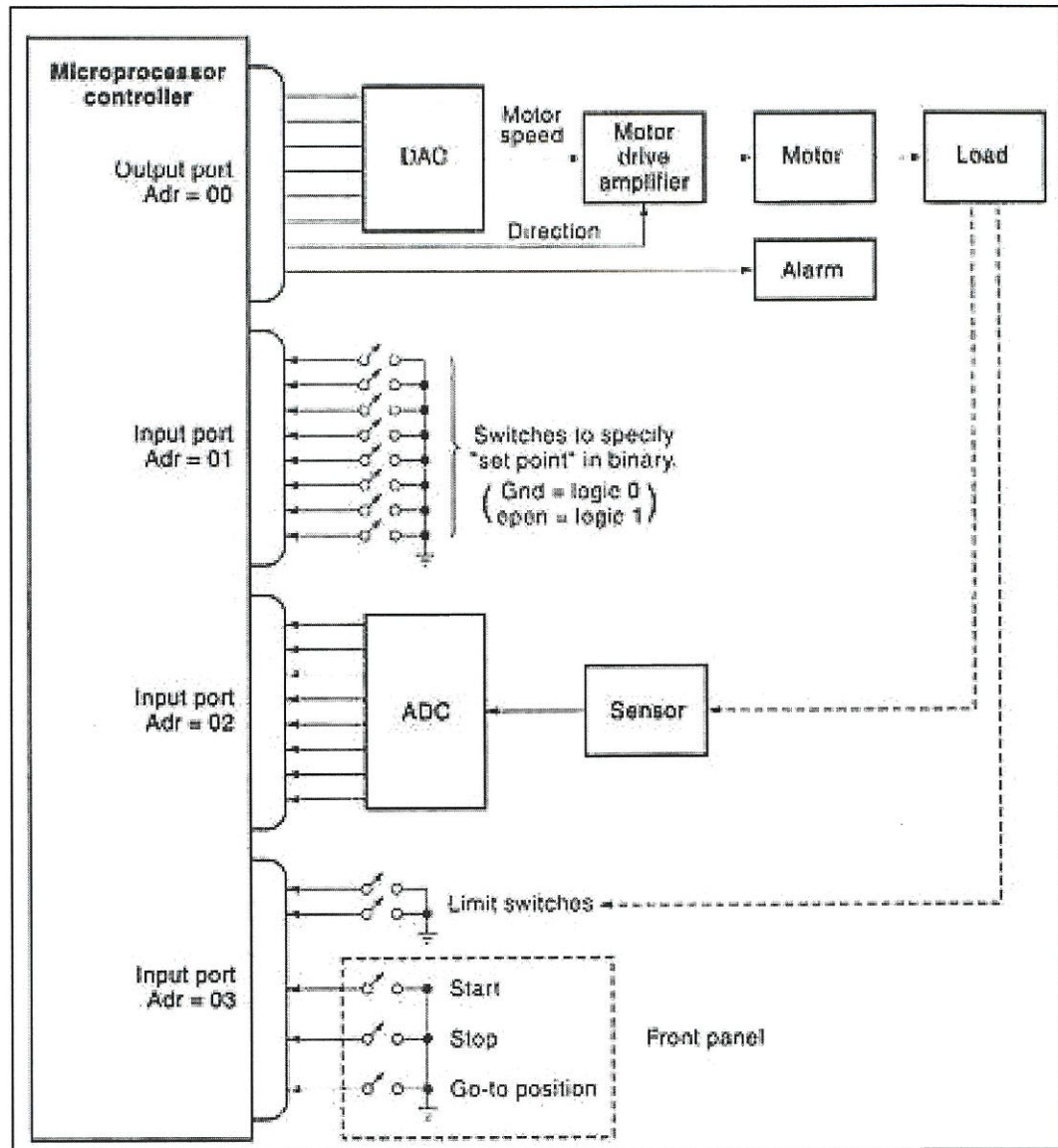

Figure Q2(b)

(8 marks)

- (c) As a Control Engineer, you have noticed the signal produced by an amplifier in your design contains noise.
- (i) Explain how to reduce the noise from the amplifier output. (1 mark)
  - (ii) Sketch the circuit diagram of your answer in Q2(c)(i). (5 marks)

(5 marks)

**TERBUKA**

CONFIDENTIAL

- (d) The height of a 50-foot tall storage tank is measured using an instrument with a 12 bit-ADC. 0 feet of water corresponds to 0% of measurement while 50 feet corresponds to 100% measurement.
  - (i) Determine how much physical water level will be represented in each *step* of the ADC. (3 marks)
  - (ii) Find the water level for step 27<sup>th</sup>, 979<sup>th</sup>, 2015<sup>th</sup> and 2020<sup>th</sup>. (4 marks)

- Q3**
- (a) Explain the reason why the following appliances are using an open loop system
    - (i) Automatic washing machine (2 marks)
    - (ii) Electric bulb (2 marks)
    - (iii) Electric hand dryer (2 marks)
  - (b) Define the input and output signal type (time & amplitude) of each block for an Analog to Digital (ADC) shown in **Figure Q3(b)**.

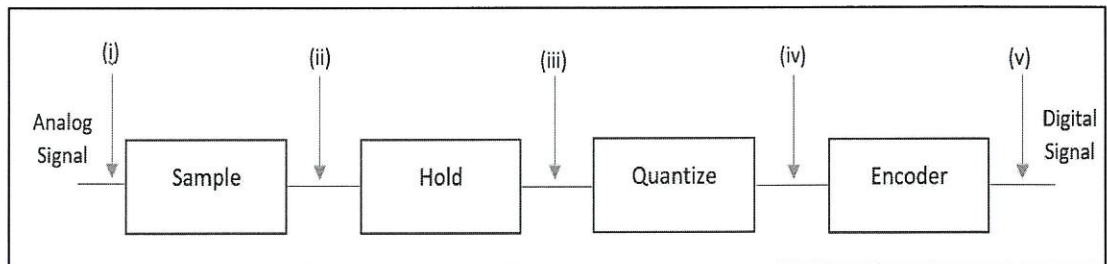

**Figure Q3(b)**

(10 marks)

- (c) Calculate the resolution of a 10-bit DAC and find the binary value of the input if the output shows 7.5 VDC over 12 V<sub>ref</sub>. (5 marks)
- (d) Give your opinion why digital control system is superior than analog control system in terms of:
  - (i) Cost (2 marks)
  - (ii) Flexibility (2 marks)

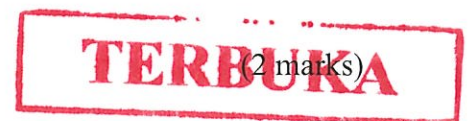

- Q4** (a) A second order system has a Damping ratio = 0.25 and Natural frequency = 4. State the closed loop transfer function when  $H(s) = 5$ . (2 marks)

- (b) Find the transfer function for the RLC circuit shown in **Figure Q4(b)**.

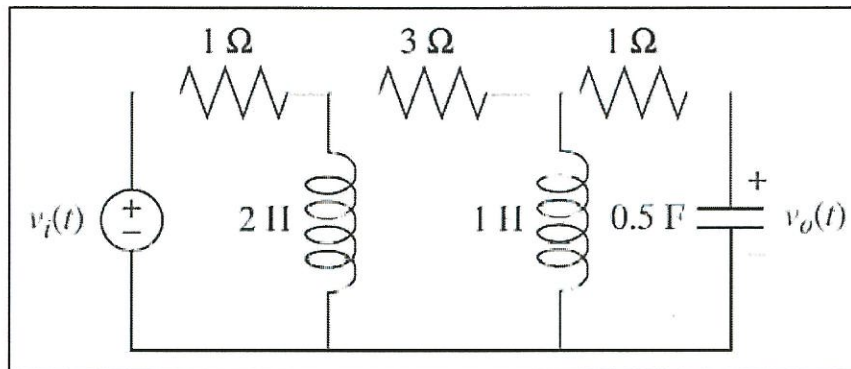

**Figure Q4(b)**

(8 marks)

- (c) Reduce the block diagram shown in **Figure Q4(c)** into a single block diagram.

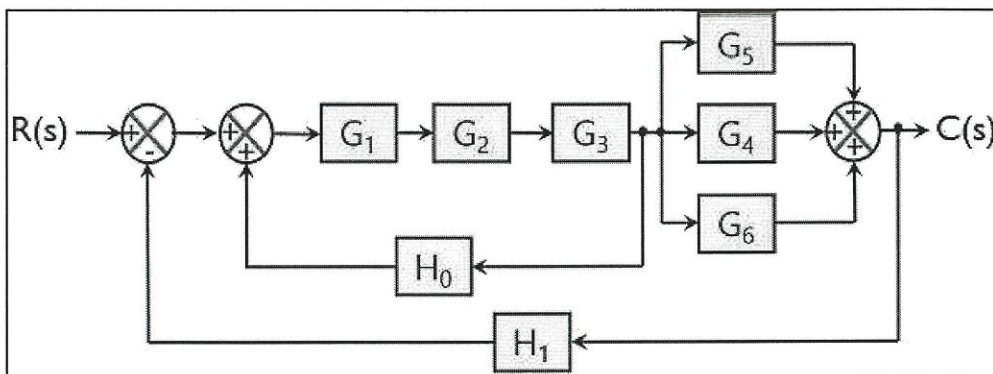

**Figure Q4(c)**

(5 marks)

- (d) A unity-feedback control system has the following closed-loop transfer function.

$$T(s) = \frac{C(s)}{R(s)} = \frac{Ks + b}{s^2 + as + b}$$

- (i) Find  $G(s)$ . (4 marks)
- (ii) Show that the steady state error for a ramp input,  $R(s) = \frac{1}{s^2}$ , is given by:

$$e_{ramp}(\infty) = \frac{a - K}{b}$$

**TERBUKA**  
(3 marks)

- (e) **Figure Q4(e)** shows the step response of a closed loop system controlled by a Proportional, P-controller. A Derivative component is then added to the controller. Predict with an illustration, the changes made to the step response.

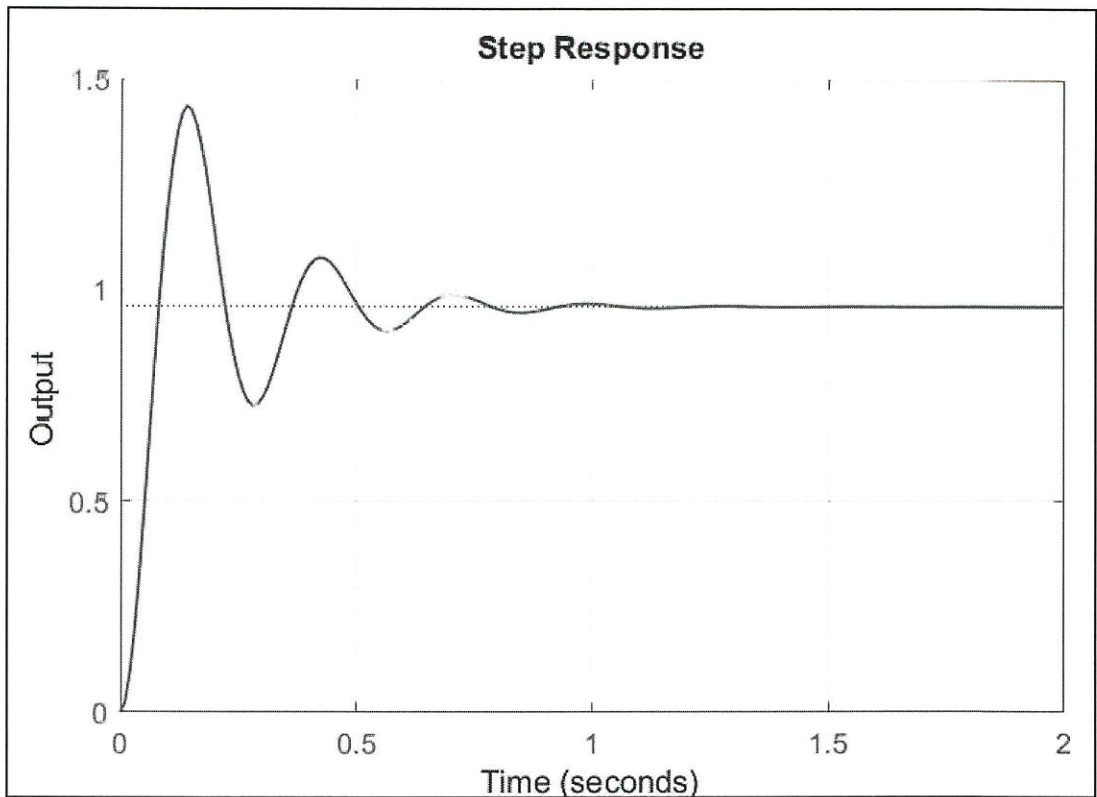

**Figure Q4(e)**

(3 marks)

- Q5** (a) State the significance of pole-zero plot in control system design.
- (b) Find the ramp response for the following transfer function.

$$T(s) = \frac{2s^2}{s^2 + 7s + 12}$$

(4 marks)



- (c) Determine the stability of the closed loop control system shown in **Figure Q5(c)**.

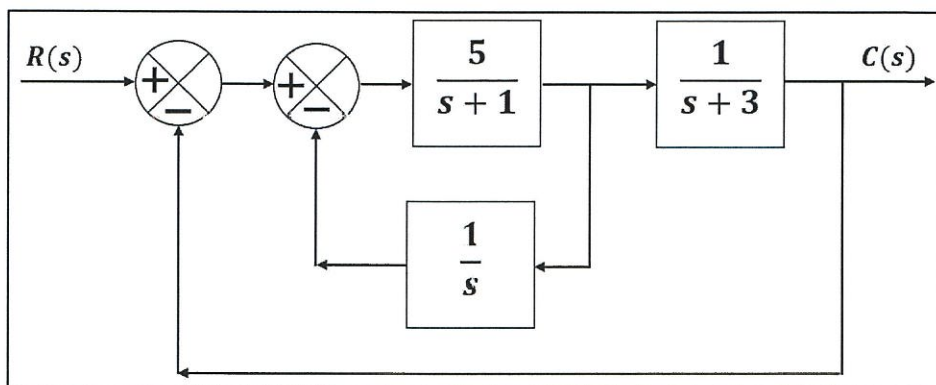

Figure Q5(c)

(8 marks)

- (d) A PID controller is used to control a line follower robot. Describe the effects of proportional co-efficient to the system when it is tuned too low and too high. (4 marks)
- (e) **Figure Q5(e)** shows the output response of a PID controlled closed loop system when a step input of Final value = 1 is applied to it.

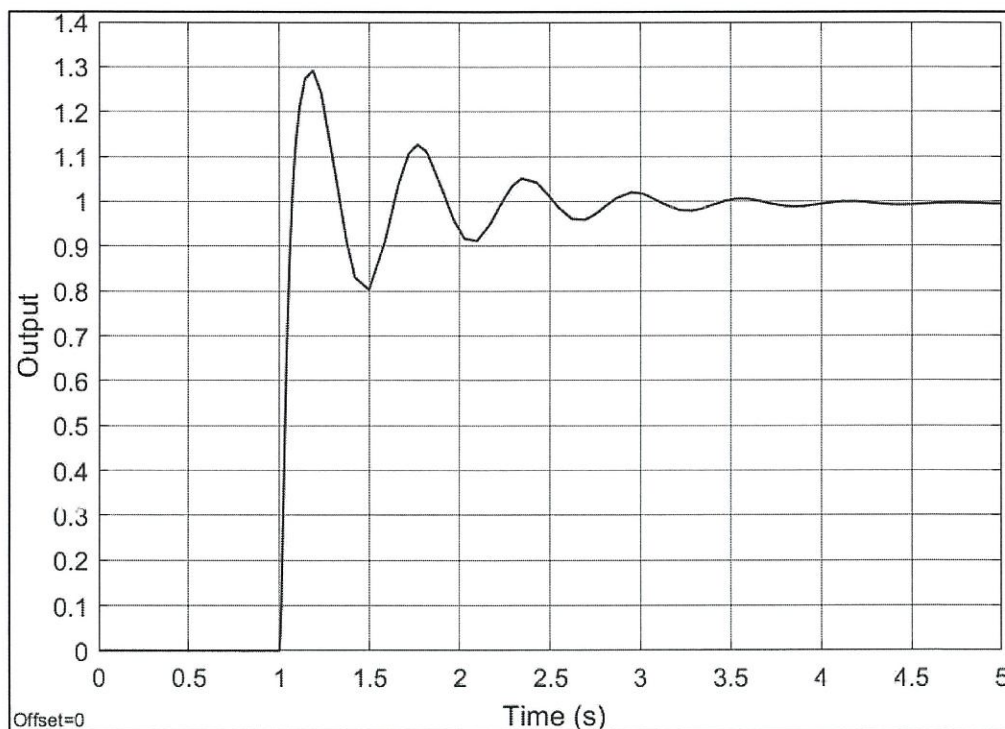

Figure Q5(e)

- (i) Identify the type of response. (1 mark)
- (ii) Interpret the graph to get meaningful values. (4 marks)

**TERBUKA**



- Q6** (a) Recall the impact of decreasing damping ratio to the system response. (2 marks)
- (b) Given the reference input for an air-conditioning closed loop control system is 20°C. Illustrate the 2% settling time criterion and 10% maximum overshoot for the control system. (3 marks)
- (c) A PID controller is added to the unity feedback system shown in **Figure Q6(c)**. The transfer function of the PID controller is,

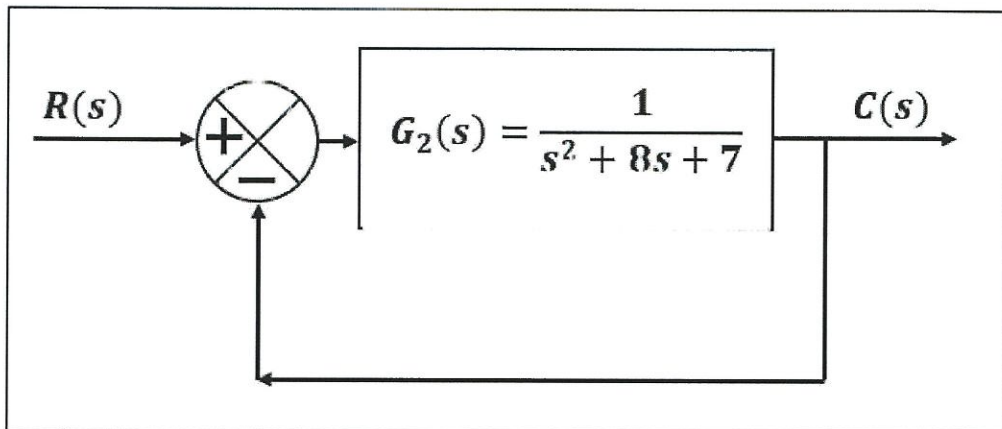

**Figure Q6(c)**

$$G_1(s) = \frac{s^2 + 5s + 4}{s}$$

- (i) Identify the co-efficient for Proportional ( $K_p$ ), Integral ( $K_i$ ) and Derivative ( $K_d$ ). (3 marks)
- (ii) A step input with a Final value = 1 is applied to the system. Compare the steady state error percentage of the system without a PID controller and with a PID controller. (5 marks)

**TERBUKA**

(d) **Figure Q6(d)** shows a control system for a shell and tube heat exchanger.

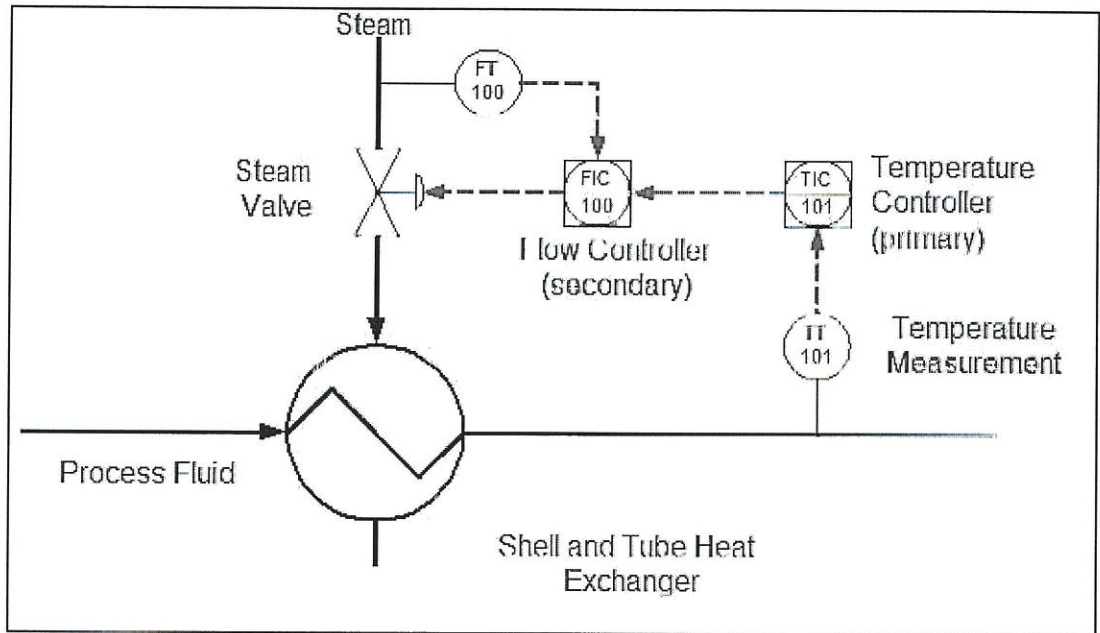

**Figure Q6(d)**

- (i) Identify the type of control system implemented. (1 marks)
- (ii) Draw the complete block diagram of the system. (6 marks)
- (iii) Describe the operation of the system. (5 marks)

– END OF QUESTIONS –

**TERBUKA**

FINAL EXAMINATION

SEMESTER / SESSION : SEM I / 2020/2021  
 COURSE NAME : CONTROL SYSTEM

PROGRAMMECODE : DAE  
 COURSE CODE : DAE 32103

LIST OF FORMULAE: Laplace Transform Table

$f(t), t \geq 0$	$F(s)$
1. $\delta(t)$	1
2. $u(t)$	$\frac{1}{s}$
3. $t$	$\frac{1}{s^2}$
4. $t^n$	$\frac{n!}{s^{n+1}}$
5. $e^{-at}$	$\frac{1}{s + a}$
6. $t e^{-at}$	$\frac{1}{(s + a)^2}$
7. $t^n e^{-at}$	$\frac{n!}{(s + a)^{n+1}}$
8. $\sin bt$	$\frac{b}{s^2 + b^2}$
9. $\cos bt$	$\frac{s}{s^2 + b^2}$
10. $e^{-at} \sin bt$	$\frac{b}{(s + a)^2 + b^2}$
11. $e^{-at} \cos bt$	$\frac{s + a}{(s + a)^2 + b^2}$
12. $t \sin bt$	$\frac{2bs}{(s^2 + b^2)^2}$
13. $t \cos bt$	$\frac{s^2 - b^2}{(s^2 + b^2)^2}$

**TERBUKA**

FINAL EXAMINATION

SEMESTER / SESSION : SEM I / 2020/2021  
 COURSE NAME : CONTROL SYSTEM

PROGRAMMECODE : DAE  
 COURSE CODE : DAE 32103

LIST OF FORMULAE: Block Diagram Transformation

	Original Block Diagrams	Equivalent Block Diagrams
1		
2		
3		
4		
5		

**TERBUKA**