

**CONFIDENTIAL**



**UTHM**  
Universiti Tun Hussein Onn Malaysia

**UNIVERSITI TUN HUSSEIN ONN MALAYSIA**

**FINAL EXAMINATION  
SEMESTER II  
SESSION 2021/2022**

COURSE NAME : QUALITY CONTROL  
COURSE CODE : BPB 24303  
PROGRAMME : BPB  
EXAMINATION DATE : JULY 2022  
DURATION : 2 HOURS AND 30 MINUTES  
INSTRUCTION : 1. ANSWER **ALL** QUESTIONS  
2. THIS FINAL EXAMINATION IS CONDUCTED VIA CLOSED BOOK.  
3. STUDENTS ARE PROHIBITED TO CONSULT THEIR OWN MATERIAL OR ANY EXTERNAL RESOURCES DURING THE EXAMINATION CONDUCTED VIA CLOSED BOOK

THIS QUESTION PAPER CONSISTS OF **SIX (6)** PAGES

**CONFIDENTIAL**

**TERBUKA**

- Q1** (a) Develop a flow-chart starting from identifying problem until standardization with appropriate basic seven quality control (QC) tools and new seven QC tools in each step. (10 marks)
- (b) AMX company has quality issues in their production line. The quality control department has identified the actual causes of the problems as presented in **Table Q1(b)**.

**Table Q1(b): Actual causes of quality problem**

NO	CAUSES	QUANTITY
1	Part failure	45
2	Machine breakdown	35
3	SOP problem	5
4	Workplace unorganised	3
5	Improper schedule for 5S	3
6	Workplace problem	3
7	Plastic part bending	2
8	Work miss	2
9	Lack of co-operation	1
10	Lack of awareness	1

Based on **Table Q1(b)**

- (i) Draw Affinity diagram. (6 marks)
- (ii) Explain the applicability of 80/20 rule for this problem. (3 marks)
- (iii) Propose **TWO (2)** solutions for improvement based on main cause as stated in **Table Q1(b)** using Tree Diagram. (6 marks)

**Q2** Measurement data for the np chart collected is shown in **Table Q2**.

**Table Q2: Measurement Data for np chart**

SAMPLE	SAMPLE QUANTITY	DEFECTS	PROPOSITION
1	100	9	0.09
2	100	14	0.14
3	100	10	0.10
4	100	8	0.08
5	100	15	0.15
6	100	9	0.09
7	100	9	0.09
8	100	8	0.08
9	100	10	0.10
10	100	1	0.01
11	100	12	0.12
12	100	19	0.19
13	100	7	0.07
14	100	13	0.13
15	100	14	0.14
16	100	12	0.12
17	100	11	0.11
18	100	15	0.15
19	100	9	0.09
20	100	17	0.17
21	100	10	0.10
22	100	21	0.21
23	100	26	0.26
24	100	18	0.18
25	100	15	0.15
26	100	15	0.15
27	100	29	0.29
Sum			

Calculate:

- (a)  $\bar{P}$  (2 marks)
- (b)  $\bar{n}$  (2 marks)
- (c) Upper Control Limit (UCL). (3 marks)
- (d) Lower Control Limit (LCL). (3 marks)



- (e) Construct np chart based on **Table Q2**. (10 marks)
- (f) Analyse the np chart based on the result in **Q2**. (5 marks)

**TERBUKA**

**Q4** (a) Discuss **THREE (3)** types of phase in life history curve. (6 marks)

(b) Differentiate between reliability and durability. (3 marks)

(c) A system has six components,  $P_1, P_2, P_3, P_4, P_5,$  and  $P_6,$  with reliability values of 0.895, 0.882, 0.879, 0.799, 0.880, 0.819 respectively.

Calculate the system reliability if the components are in series. (3 marks)

(d) A system of circuit has five components, A, B, C, D and E, with reliability values of 0.772, 0.767, 0.788, 0.688 and 0.776, respectively.

Calculate the system reliability if the components are in parallel. (3 marks)

(e) Calculate the reliability of the system in **Figure Q4(e)**. (4 marks)

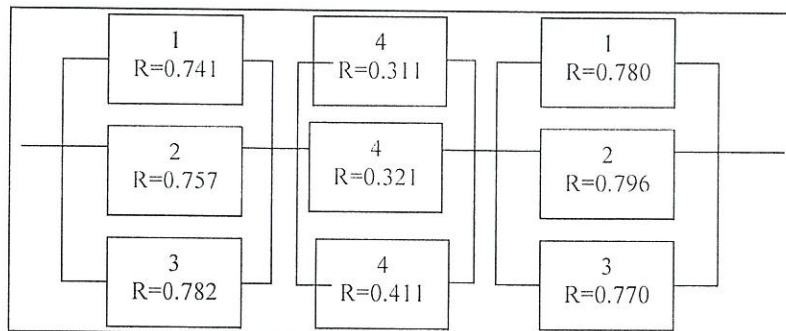

**Figure Q4(e): Reliability in Parallel and Series**

(f) AKZ company has conducted life test on 100 units of LCD-TV. Based on the life test result, five units of speaker failed after 110, 120, 140, 160 and 170 hours during life test and 95 units were still functioning at the end of 200 hours.

Calculate:

(i) Failure rate at the end of 200 hours. (3 marks)

(ii) Mean life based on failure rate from Q4(e)(i). Assume that there is a constant failure rate for the test. (3 marks)

**-END OF QUESTIONS-**

**TERBUKA**