

CONFIDENTIAL



UTHM
Universiti Tun Hussein Onn Malaysia

UNIVERSITI TUN HUSSEIN ONN MALAYSIA

**FINAL EXAMINATION
SEMESTER II
SESSION 2022/2023**

COURSE NAME : MICROCONTROLLER
COURSE CODE : DAE 32203
PROGRAMME CODE : DAE
EXAMINATION DATE : JULY / AUGUST 2023
DURATION : 3 HOURS
INSTRUCTION : 1. ANSWER **ALL** QUESTIONS
2. THIS FINAL EXAMINATION IS
CONDUCTED VIA **CLOSED BOOK**.
3. STUDENT ARE **PROHIBITED** TO
CONSULT OWN MATERIALS OR
ANY EXTERNAL RESOURCES
DURING THE EXAMINATION
CONDUCTED VIA CLOSED BOOK.

THIS QUESTION PAPER CONSISTS OF **TWELVE (12)** PAGES

CONFIDENTIAL

TERBUKA

PART A: ANSWER ALL QUESTIONS

(1 mark each)

- Q1** Which one is the best explanation for microcontroller?
- A. small CPU made of transistors and conductors of heat and sound sensor
 - B. small computer on a single integrated circuit containing a processor core, memory, and programmable input/output peripherals
 - C. portable circuits capable of making other circuits
 - D. small chip made of silver
- Q2** How many external interrupt pins at Arduino UNO ?
- A. 1
 - B. 2
 - C. 3
 - D. 4
- Q3** Based on **Figure Q3**, what is the digital value read on pin 2 when the push button is pressed?

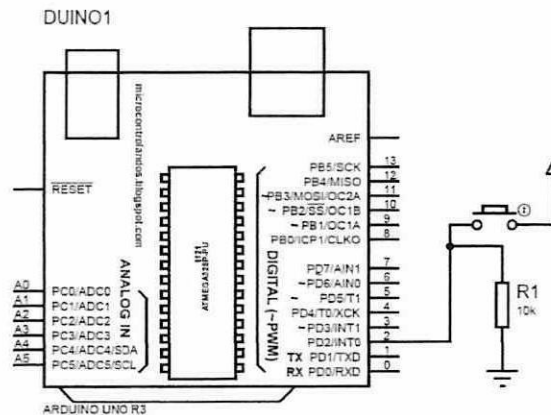

Figure Q3

- A. LOW
 - B. HIGH
 - C. RISING
 - D. FALL
- Q4** A microcontroller at-least should consist of:
- A. RAM, ROM, I/O devices, serial and parallel ports and timers
 - B. CPU, RAM, I/O devices, serial and parallel ports and timers
 - C. CPU, RAM, ROM, I/O devices, serial and parallel ports and timers
 - D. CPU, ROM, I/O devices and timers
- Q5** All of following are non-volatile memory except
- A. ROM
 - B. EPROM
 - C. Flash Memory
 - D. RAM

Q6 Which of the following condition is TRUE after the code is applied for variable STATE when the button is pressed based on the sequence shown in **Figure Q6**?

```
volatile byte STATE = LOW;

void setup() {
  attachInterrupt(0, ISR0, FALLING)
}

void loop() {}

void ISR0() {
  STATE = !STATE;
}
```

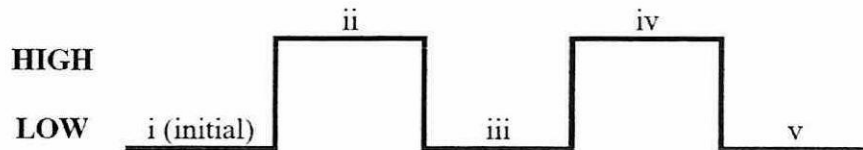

Figure Q6

- A. (i)LOW→(ii)LOW →(iii) HIGH → (iv)HIGH → (v)LOW
- B. (i)LOW→(ii)HIGH→(iii) LOW→ (iv)HIGH → (v)LOW
- C. (i)HIGH→(ii)LOW→(iii) HIGH→ (iv)HIGH → (v)LOW
- D. (i)LOW→(ii)LOW→(iii) LOW→ (iv)HIGH → (v)LOW

Q7 What is wrong with the following program?

```
/*Turns on an LED for one second, then turn off for one second,
repeatedly. This example code is in the public domain.*/

int led = 13;

void setup() {
  pinMode(led, INPUT);
}

void loop() {
  digitalWrite(led, HIGH);
  delay(1000);
  digitalWrite(led, LOW);
  delay(1000);
}
```

- A. pinMode(led,INPUT);
- B. digitalWrite(led, HIGH);
- C. delay(1000);
- D. int led = 13;

Q8 For circuit in **Figure Q8**, if the following program is used, what should be observed from the LED?

```
void setup() {
    pinMode(9, OUTPUT);
    pinMode(6, INPUT);
}
void loop() {
    digitalWrite(9, HIGH);
    delay (1000);
    digitalWrite(9, LOW);
}
```

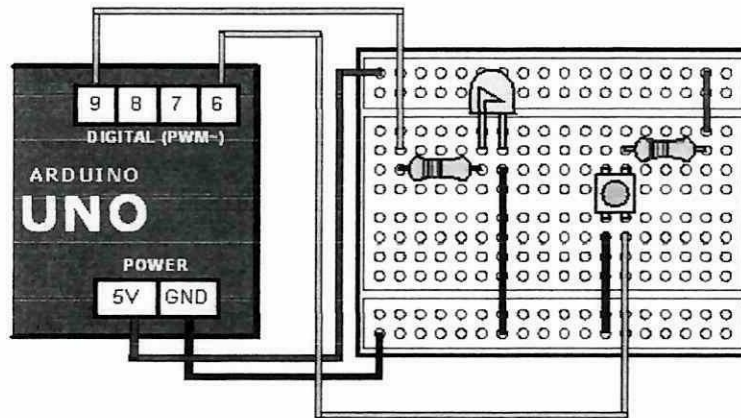

Figure Q8

- A. LED will turn ON for 1s and OFF
- B. LED will turn ON for 1s and OFF for 1s and repeat
- C. LED will turn ON for 1s and OFF for 1s
- D. LED will seemingly ON all the time

Q9 Referring to circuit in **Figure Q8**, if the code below is used, describe the circuit functionality.

```
void setup() {
    pinMode(9, OUTPUT);
    pinMode(6, INPUT);
}
void loop() {
    if (digitalRead(6)==LOW)
        digitalWrite(9, HIGH);
    else
        digitalWrite(9, LOW);
}
```

- A. LED will turn ON no matter if button is pushed or released.
- B. LED will turn ON if button is pushed and OFF when button is released.
- C. LED will turn OFF no matter if button is pushed or released.
- D. LED will turn OFF if button is pushed and ON when button is released.

Q10 Which of the following statements describes a true outcome from executing the two Arduino statements?

```
pinMode(5, OUTPUT);  
analogWrite(5, 128);
```

- A. A pulse-width modulated signal is generated for 128 milliseconds
- B. A square wave is generated on channel 5 that is used to approximate 2.51V
- C. A square wave signal with a pulse height of 128mV is sent to channel 5
- D. An error because the pinMode statement should use ANALOG not OUTPUT

Q11 Which timer register is used to indicate a pending timer interrupt?

- A. TCCR_x
- B. TCNT_x
- C. TIMSK_x
- D. TIFR_x

Q12 What does pinMode(13, INPUT_PULLUP) for?

- A. Setting pin 13 as input with internal pullup enabled, thus will give HIGH when it is not pulled to LOW.
- B. Setting pin 13 as input with internal pullup enabled, thus will give LOW when it is not pulled to HIGH.
- C. Setting pin 13 as input, the configuration is equal to INPUT.
- D. Setting pin 13 as input with internal pullup enabled, thus will give continuously LOW.

Q13 Arduino Uno can source (provide current) or sink (absorb current) up to:

- A. 40 mA
- B. 100 mA @ 9 V
- C. 4 mA
- D. 100 mA

Q14 How many times will the loop run for the following code?

```
int a;  
for (a = 1; a < 16; a++) {  
  Serial.println(a);  
}
```

- A. 13
- B. 14
- C. 15
- D. 16

Q15 How do you access a variable in an array?

- A. access code
- B. variable search
- C. parsing method
- D. index number



Q16 Any code that's written inside the if block shown below will:

```
if (1)
{
}

```

- A. Show an error
- B. Show a warning but not an error
- C. Execute infinitely
- D. Print '1'

Q17 All statements below are true EXCEPT

- A. Timer is a piece of hardware built in the Arduino controller and can be used to measure time events.
- B. The timer hardware can be configured with some special timer registers such as the pre-scaler for the timer, or the mode of operation and many other things
- C. In the Arduino firmware, all timers were configured to a 1kHz frequency and interrupts are generally disabled
- D. All timers depends on the system clock of your Arduino system and normally the system clock is 16MHz.

Q18 Based on Figure Q18, what is the function of components R15 and R16??

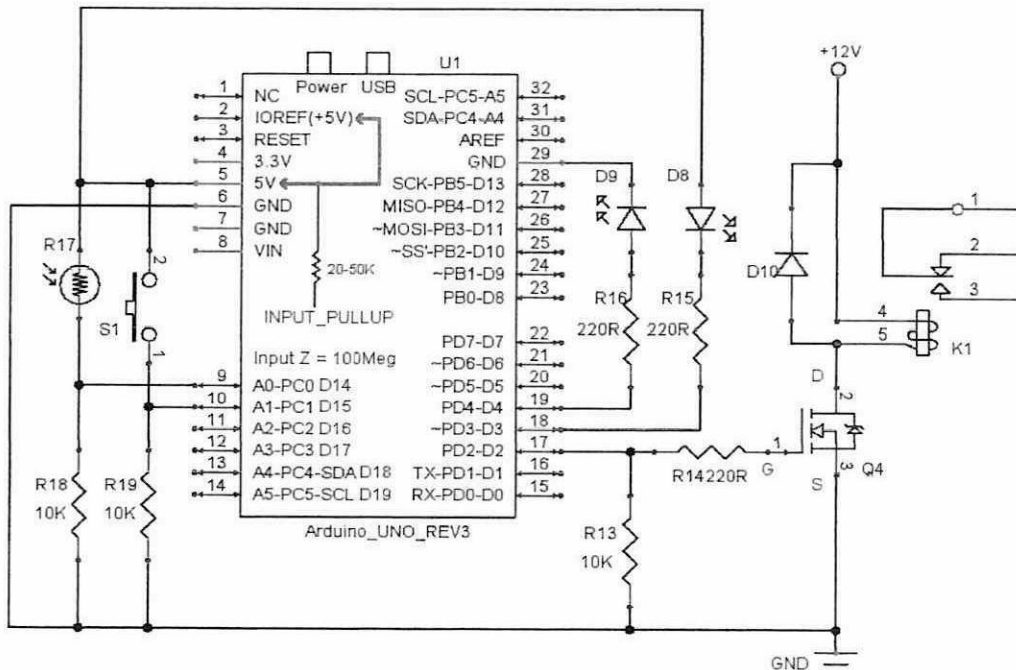

Figure Q18

- A. Pull-up resistor
- B. Pull-down resistor
- C. Current limiting resistor
- D. Voltage limiting resistor

Q19 Which of the following statements describes the outcome from the following program?

```
const byte LED1 = 8 ;
const unsigned long LED1interval = 1000 ;
unsigned long LED1timer = 0 ;
int LED1State = LOW
void setup() {
  pinMode (LED1,OUTPUT) ;
  LED1timer = millis () ;
}
void loop()
if ( (millis () - LED1timer ) >= LED1interval ) {
  if (LED1State == LOW)
    LED1State = HIGH ;
  else
    LED1State = LOW ;
digitalWrite (LED1, LED1State ) ;
LED1timer = millis () ;
}
```

- | | |
|---|--|
| A. The LED1 will blinks with 1 second interval with initial state of LED1 is on | C. The LED1 will blinks with 1 second interval with initial state of LED1 is off |
| B. Show an error | D. Show a warning but not an error |

Q20 The following program is to rotate a servo motor by discrete angular positions. Which code need to be modify to optimize the positions controlled by the potentiometer?

```
#include <Servo.h>
Servo myservo;
int value;
int potentio = A0;
double angle;
void setup()
{
  Serial.begin(9600);
  myservo.attach(9);
}
void loop()
{
  value = analogRead(potentio);
  angle = map(value, 0, 1023, 0, 255);
  Serial.println(angle);
  myservo.write(angle);
}
```

- | | |
|--|--|
| A. Change angle = map(value, 0, 1023, 0, 180); | C. Change angle = map(value, 1023, 0, 180, 0); |
| B. Change const byte value; | D. Add delay (10); |

- Q21** Arduino shields are also called as
- A. Extra peripherals
 - B. Add on modules
 - C. Connectivity modules
 - D. Another arduinos
- Q22** In the Arduino, what is the symbol used to calculate modulo
- A. %
 - B. #
 - C. !
 - D. \$
- Q23** What does p refer to in ATmega328p?
- A. Production
 - B. Pico-power
 - C. Power-pico
 - D. Programmable on chip
- Q24** What is the default bootloader of the Arduino UNO?
- A. Optiboot bootloader
 - B. Air-boot
 - C. Bare box
 - D. GAG
- Q25** Which is the software or a programming language used for controlling of Arduino?
- A. Assembly language
 - B. C language
 - C. JAVA
 - D. Any language
- Q26** To subtract 1 from a variable counter, you can use the following statements except:
- A. Counter - 1;
 - B. Counter -= 1;
 - C. --counter;
 - D. Counter--;
- Q27** Is there anything wrong with this line of code, if yes, what?
- ```
if(myVar = true) Serial.println("The light is ON");
```
- A. There needs to be a space after the if keyword
  - B. The line has invalid syntax, and will produce a compiler error.
  - C. The = should be ==
  - D. There is nothing wrong
- Q28** What does the word static do in this line of code?
- ```
static int temperature = 0;
```
- A. The value of temperature will not be allowed to change.
 - B. The variable will have a greater range than a normal int
 - C. The variable will be reset to 0 each time loop() runs
 - D. The variable's value is retained the next time it is accessed.

Q29 What is the value of foo when these lines of code are executed?

```
foo = 12;  
foo = foo % 10;
```

- A. 1
- B. 2
- C. 1.2
- D. 120

Q30 What does this line of code do?

```
temp = !temp;
```

- A. Performs a factorial calculation
- B. Converts the variable temp to a boolean value
- C. Sets the variable temp to its logical compliment
- D. Read the temp value



PART A - ANSWER SHEET

Q1	<input type="text"/>	Q11	<input type="text"/>	Q21	<input type="text"/>
Q2	<input type="text"/>	Q12	<input type="text"/>	Q22	<input type="text"/>
Q3	<input type="text"/>	Q13	<input type="text"/>	Q23	<input type="text"/>
Q4	<input type="text"/>	Q14	<input type="text"/>	Q24	<input type="text"/>
Q5	<input type="text"/>	Q15	<input type="text"/>	Q25	<input type="text"/>
Q6	<input type="text"/>	Q16	<input type="text"/>	Q26	<input type="text"/>
Q7	<input type="text"/>	Q17	<input type="text"/>	Q27	<input type="text"/>
Q8	<input type="text"/>	Q18	<input type="text"/>	Q28	<input type="text"/>
Q9	<input type="text"/>	Q19	<input type="text"/>	Q29	<input type="text"/>
Q10	<input type="text"/>	Q20	<input type="text"/>	Q30	<input type="text"/>

PART B: ANSWER ALL QUESTIONS

- Q1** An engineer is required to develop an operation system of a servo motor. The motor positions is controlled using a 10k ohm potentiometer with **four (4)** LEDs as the indicator of the rotation degree. The potentiometer must control the servo motor positions from 0° to 180 °. The LEDs operation is shown by **Table 1**. Write a program based on the operation stated. In your program, use Servo library to control the servo motor positions, use pin 3 for motor and pins 10-13 for LEDs
(16 marks)

Table 1

Servo position	LED 1	LED 2	LED 3	LED 4
Less than or equal to 45°	ON	OFF	OFF	OFF
Between 46° to 90°	ON	ON	OFF	OFF
Between 91° to 135°	ON	ON	ON	OFF
More than 135°	ON	ON	ON	ON

- Q2** (a) (i) Briefly explain **three (3)** components in LCD memory.
(6 marks)
- (ii) Differentiate between command and data registers in LCD.
(3 marks)
- (b) Write the correct syntax for the following statements.
- (i) Turn on blinking cursor
(ii) Display value of val in LCD.
(iii) Reset display on LCD screen
(iv) Positions the cursor in the upper-left of the LCD
(4 marks)
- (c) Write a program to read an Analog Input and display the Output on the LCD. When the Analog Input represented by a potentiometer is read, the input value is then converted to voltage value. Finally, the voltage value is displayed on the LCD continuously.
(7 marks)

