



**UNIVERSITI TUN HUSSEIN ONN MALAYSIA**

**FINAL EXAMINATION  
SEMESTER II  
SESSION 2010/2011**

**COURSE NAME** : TECHNICAL COMMUNICATION 1  
**COURSE CODE** : UWB 10402  
**PROGRAMME** : 1 DAL/DAE/DAA/DAC/DDM/dfa/dam/  
DAI/DAT/DIT  
**EXAMINATION DATE** : APRIL / MAY 2011  
**DURATION** : 2 HOURS  
**INSTRUCTION** : ANSWER ALL QUESTIONS IN THE  
ANSWER BOOKLET PROVIDED

**THIS QUESTION PAPER CONSISTS OF SIX (6) PAGES**

**Q1** In not more than 20 words, write a formal definition for each of the following terms:

- (a) A digital camera
- (b) A radio
- (c) A mobile phone
- (d) Tsunami
- (e) AIDS

(10 marks)

**Q2** Read and analyse the four situations below. Decide which type of report or proposal each situation belongs to.

(a) SITUATION 1

Dr Noor Harun is currently doing a research on the migration of the Nepalese immigrants in Malaysia. His research is only halfway done, yet he missed the deadline set by his supervisor.

What type of document should he prepare in order to report his development?

(b) SITUATION 2

Yau Sim Mei is a doctorate student who wants to write a thesis on the history of the Japanese ruling system since 17<sup>th</sup> century. In order to do her thesis, she needs to collect materials and conduct interviews in Japan, yet she has a low income.

What type of document should she propose?

(c) SITUATION 3

Mr Kamaluddin is in charge of the chemistry lab at a university. One day, while he was in the lab, an explosion took place, where two students suffered burns due to the explosion. The higher authority of the university wants to know why the explosion occurred.

What type of document should he produce?

(d) SITUATION 4

Students from UTHM went for a trip to Singapore. As requested by their lecturer, Ms Nuridah, they have to write a report to tell their classmates about the trip. What type of report should they produce?

(4 marks)

**Q3** You have been instructed by your supervisor to run a survey on the effectiveness of English and Mathematics tuition classes that had been conducted among the secondary schools students resided at Kg Pt Salih Roses. This survey would cover the students, parents and teachers as well.

Your survey questions must keep you informed about their satisfactions and suggestions that they are likely to make for the future classes.

You plan to distribute questionnaires as part of the survey. In the questionnaire, you decided to write several types of questions. Write **two (2)** examples for each of the types below:

- (a) Closed question
- (b) Opened question
- (c) Attitude question

(6 marks)

- Q4** Below is a diagram of a mechanical pencil. Write a technical description of the object which includes its physical and functional aspects in the description. You should write in not more than 150 words.

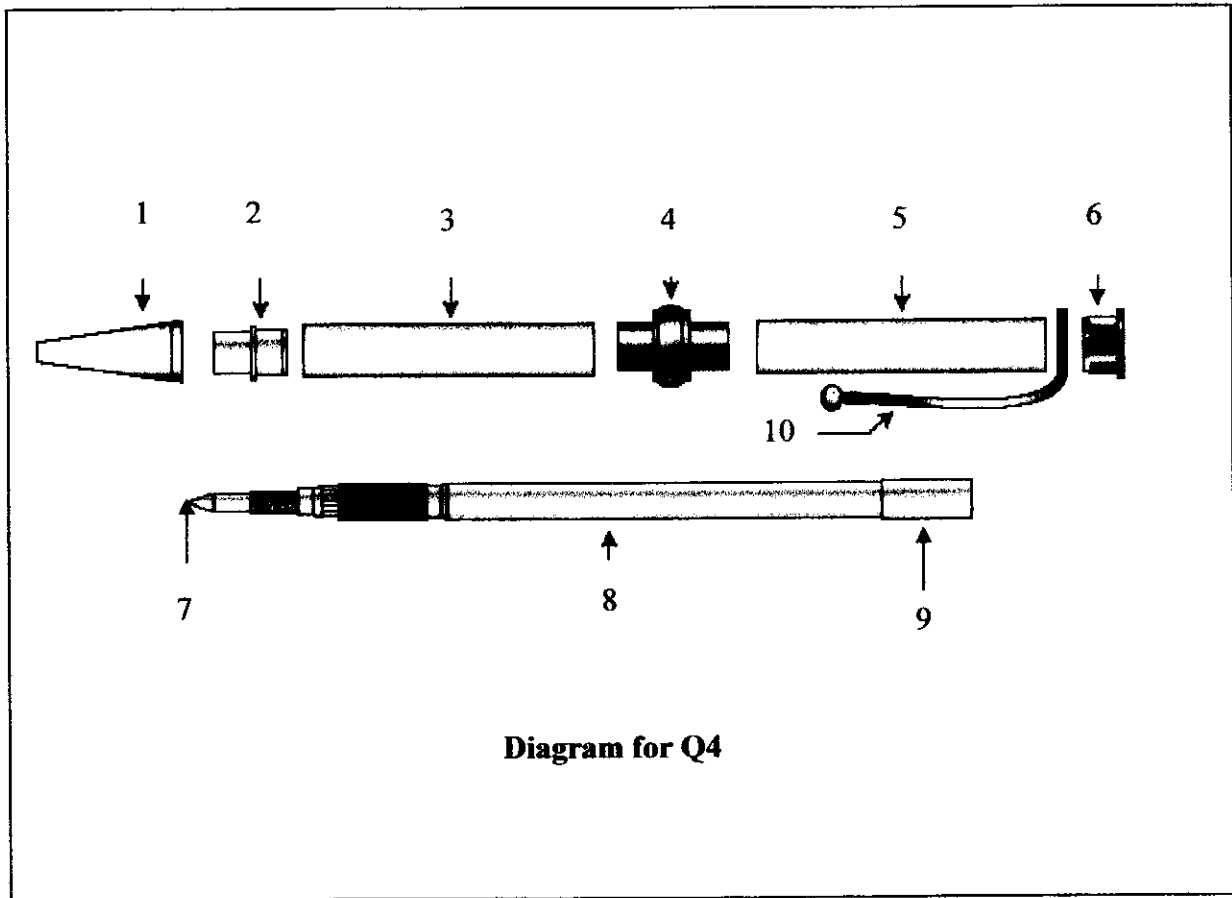

**Diagram for Q4**

**Notes:**

1. Tip - metal
2. Sleeve - see through spring
3. Lower tube (2.5cm) - plastic
4. Centre band
5. Upper tube (2.5cm) - holder
6. Cap
7. Lead - graphite, no sharpening
8. Pencil mechanism - (8cm) push lead through tip
9. Eraser - rubber, extendable
10. Clip
11. Spring - elastic, store mechanical energy

(25 marks)

**Q5** Write a field trip report based on the itinerary given below. Your report should include these elements :

- (a) Introduction
- (b) Trip objective
- (c) Methods
- (d) Results/Findings
- (e) Conclusion

(25 marks)

**A DAY TRIP TO CYBERJAYA UNIVERSITY**

**Suggested Time :** 10:00am - 1:00pm  
**Location :** CyberJaya University  
**Guests :** 30 students and 5 lecturers from UTHM, Johor.

<b>9:45am</b>	<p><b>ARRIVAL</b></p> <p>CyberJaya University staff greet students and lecturers upon arrival. Guests are directed to the selected areas around the university. Warm-up and introduction sessions about the University begin.</p>
<b>10:00am-12:30pm</b>	<p><b>VISIT TO FACULTY OF MEDIA &amp; TECHNOLOGY</b></p> <p>Students are organised into groups. The teams are then led through by a team leader each. The tour to the faculty begins. A stop at the 'product branding' workshop where students are informed on how labels or posters for products are made. Students get a chance to see samples of labels and posters on display. There will be question and answer session between the guests and the host.</p>
<b>12:30pm</b>	<p><b>LUNCH</b></p> <p>Students are directed to the University's bistro for a lunch break.</p>
<b>1:00pm</b>	<p><b>TOUR CONCLUDES</b></p> <p>Wrap-up session by the host. The University staff escort the guests back to the bus.</p>

**Q6** You are the newly appointed President of the Public Speaking Club in your college. You are requested by your club advisor to organise a public speaking competition to boost confidence among students so that they are able to speak up in public. Write a proposal to the advisor about the planning of the competition, and it should include the following components:

- (a) Problem Definition
- (b) Objectives
- (c) Proposed Solutions
- (d) Benefits
- (e) Programme and resources
- (f) Cost

(30 marks)