



**UTHM**

Universiti Tun Hussein Onn Malaysia

**UNIVERSITI TUN HUSSEIN ONN MALAYSIA**

**FINAL EXAMINATION  
SEMESTER II  
SESSION 2018/2019**

COURSE NAME : DESIGN FOR MANUFACTURE  
AND ASSEMBLY

COURSE CODE : BDD 40103

PROGRAMME : 4 BDD

EXAMINATION DATE : JUNE/JULY 2019

DURATION : 3 HOURS

INSTRUCTION : ANSWER ANY **FIVE (5)**  
QUESTIONS **ONLY** FROM SIX (6)  
QUESTIONS

THIS QUESTION PAPER CONSISTS OF SEVEN (7) PAGES

**TERBUKA**  
**CONFIDENTIAL**

- Q1** (a) Please discuss the roles of 'Concept Development and Testing' in the new product development (NPD) process. (10 marks)
- (b) Select and justify **FIVE (5)** characteristics of successful new product development (NPD) process. (10 marks)
- Q2** (a) List and discuss **THREE (3)** reasons 'Where to Apply DFMA'? (10 marks)
- (b) In simplicity where the minimize number of parts are crucial, list and discuss **THREE (3)** principles 'How to Keep Part Count Minimum'? (10 marks)
- Q3** (a) In **Figure Q3**, analyze and discuss **THREE (3)** 'Properties' that give significance impact to the product quality? (10 marks)
- (b) Analyze the factors that influence the 'Reliability of material supplies' in product manufacturing. (10 marks)
- Q4** (a) In **Figure Q4(a)**, calculate Improvement Potential (IP) by giving several options and rate the product with the best solution. (10 marks)
- (b) By referring **Figure Q4(b)**, evaluate the roles of DFMA in 'Potential for Life Cycle Cost Savings'. (10 marks)
- Q5** (a) By referring **Figure Q5(a)**, please propose and justify the possibility of improvement in the design for machining on mechanical shaft fabrication in the aspects of DFMA roles. (8 marks)
- (b) Due to the application of high cutting speed, please justify with **FOUR (4)** reasons why total production cost increased after 600 FPM (feed per minute), as tolerance and surface finish becomes increasingly fine. Refer **Figure Q5(b)** as reference. (12 marks)

- Q6** (a) Injection molding is the most commonly used manufacturing process but due to its intricacies product designers need to make adequate design considerations to ensure that part designs focus on maximizing molding performance and reducing tooling costs an area that often plague the injection molding industry. One of the DFMA part design considerations is about 'Radius'. By referring **Figure Q6(a)** give the reasons and justify why 'Radius' is important.
- (10 marks)
- (b) DFMA provides design guidelines for sheet metal designer which helps to develop better quality parts at reduced cost. By referring to **Figure Q6(b)**, please appraise the DFMA requirements from 'Punching until Lancing'.
- (10 marks)

- END OF QUESTION -

**FINAL EXAMINATION**

SEMESTER/SESSION : SEM II/2018/2019  
COURSE NAME : DESIGN FOR MANUFACTURE  
AND ASSEMBLY

PROGRAMME : BDD  
COURSE CODE : BDD 40103

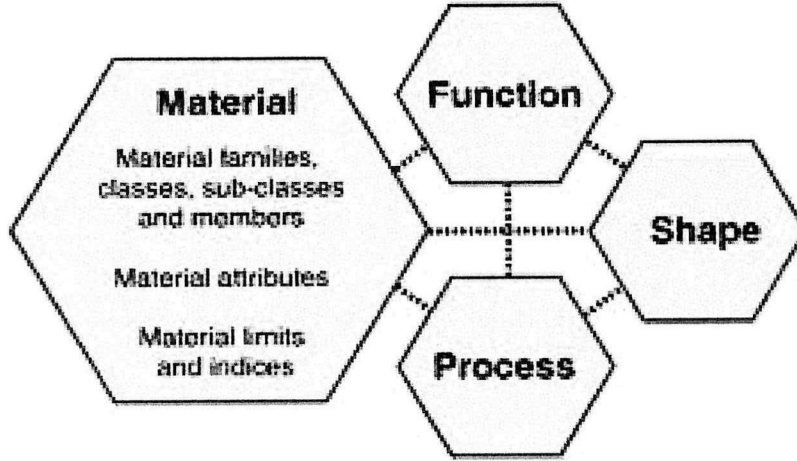

Figure Q3

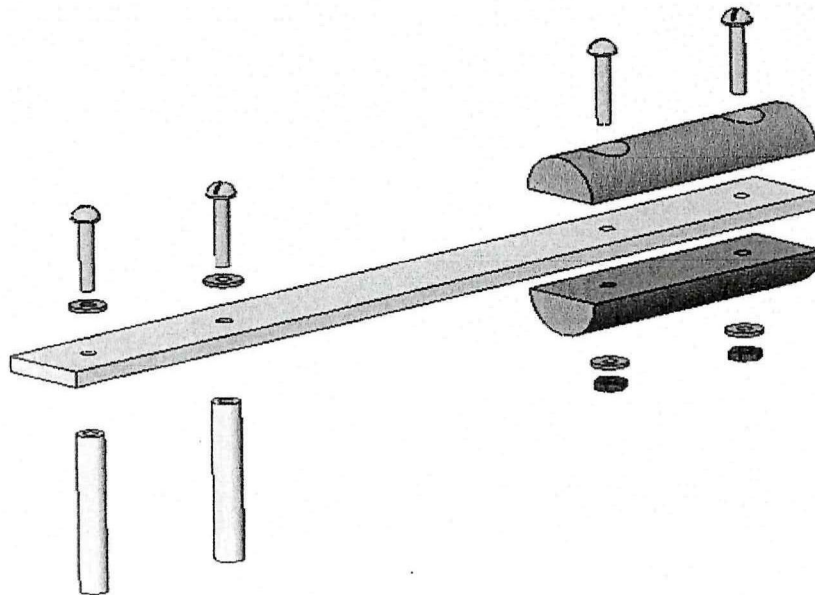
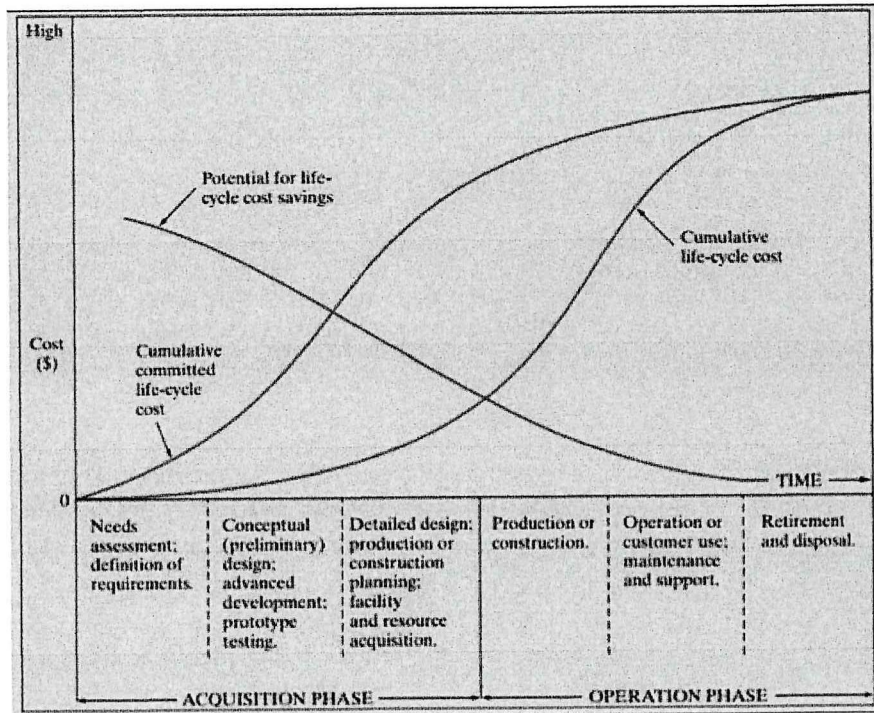

Figure Q4(a)

**FINAL EXAMINATION**

SEMESTER/SESSION : SEM II/2018/2019  
 COURSE NAME : DESIGN FOR MANUFACTURE  
 AND ASSEMBLY

PROGRAMME : BDD  
 COURSE CODE : BDD 40103



**Figure Q4(b)**

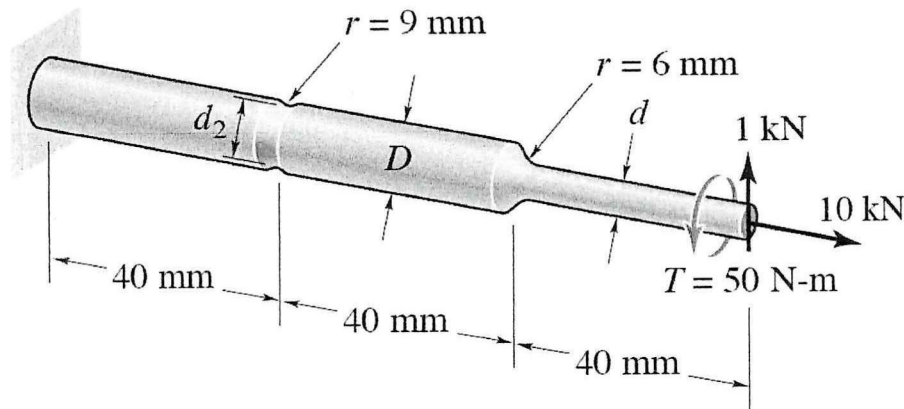

**Figure Q5(a)**

FINAL EXAMINATION

SEMESTER/SESSION : SEM II/2018/2019  
COURSE NAME : DESIGN FOR MANUFACTURE  
AND ASSEMBLY

PROGRAMME : BDD  
COURSE CODE : BDD 40103

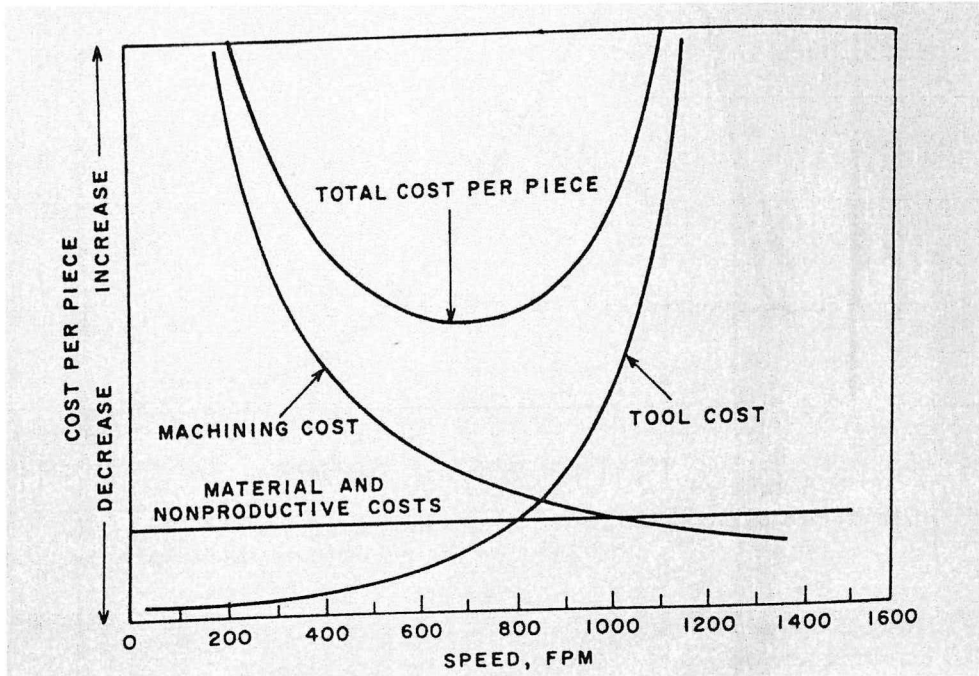

Figure Q5(b)

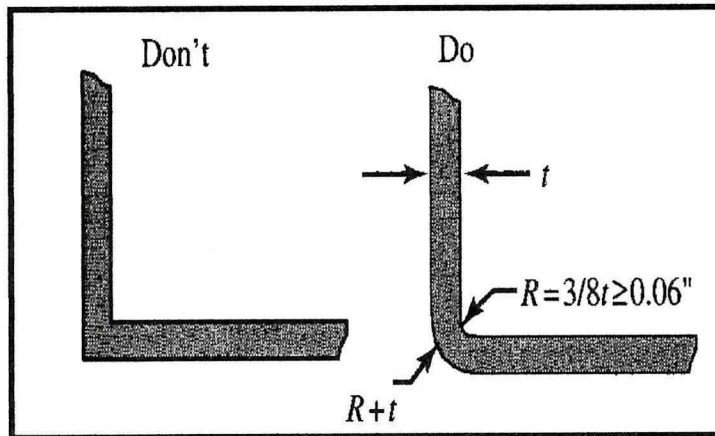

Figure Q6(a)

TERBUKA

CONFIDENTIAL

**FINAL EXAMINATION**

SEMESTER/SESSION : SEM II/2018/2019  
COURSE NAME : DESIGN FOR MANUFACTURE  
AND ASSEMBLY

PROGRAMME : BDD  
COURSE CODE : BDD 40103

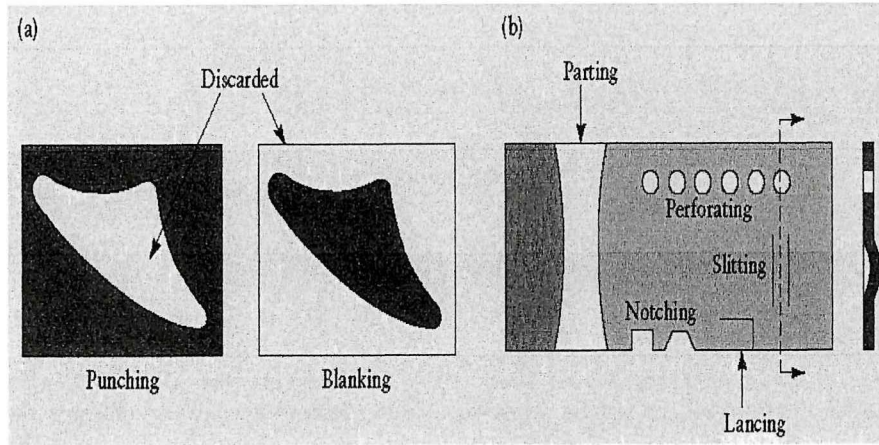

**Figure Q6(b)**